

USE OF KINETIC PLOTS FOR RELATIVE ASSESSMENT OF REACTOR THROUGHPUT AND ENERGY CONSUMPTION

S. Prakash, H. S. Ray and K. N. Gupta*

NATIONAL METALLURGICAL LABORATORY, JAMSHEDPUR 831007

*REGIONAL RESEARCH LABORATORY, BHUBANESHWAR 751013, INDIA

(Received August 19, 1991; in revised form January 3, 1992)

The progress of high temperature processes is generally described in terms of variation of the degree of conversion (α) with time (t). The present paper outlines a procedure for making use of α - t plots for comparative assessment of productivity and energy requirements for a test system with respect to a reference, on the basis of some simplifying assumptions. It is assumed that the throughput is inversely proportional to reaction time as in the case of batch reactors and plug flow reactors. It is also assumed that the energy requirement is a simple function of process temperature. The principles outlined is illustrated with reference to some laboratory data for reduction of iron oxide by coal.

Keywords: energy consumption, kinetic plots, reactor throughput

Introduction

The progress of high temperature processes is often described by isothermal kinetic plots for different temperatures. Each plot shows the isothermal variation of the degree of conversion (α) with the reaction time (t) under specific conditions. The plot is shifted upwards by increase in temperature and reactivity of raw materials. Therefore, a judicious analysis should be able to yield useful information on productivity and energy consumption at least on a comparative basis. A novel approach is presented here for such analysis of kinetic data generated for reduction of iron ore by solid and gaseous reductants under varying conditions. The principles of the approach has been discussed in details elsewhere [1, 2]. The basic philosophy and approach presented, however, are applicable to all reaction systems.

Theory

Consider Fig. 1 which shows two hypothetical sets of α - t plots for two sets of raw materials of which one is taken as the reference.

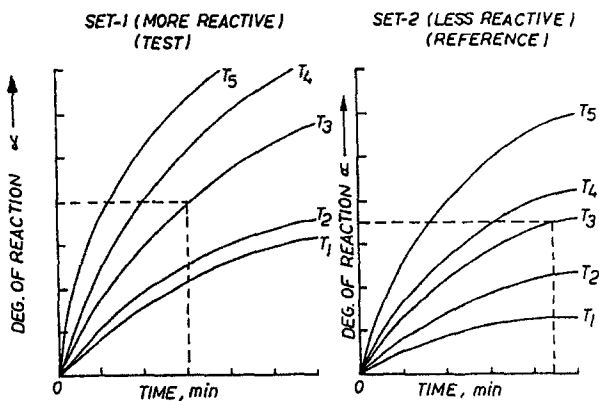

Fig. 1 Schematic α - t plots for two sets of raw materials (isothermal)

Assessment of reactor throughput

Compare the α - t plots for the test system with the reference system for a fixed temperature. The α - t plots for Set 1 are obviously placed higher because of higher reactivity of raw materials. That is, at any given value, the time required for the test system is less which implies reactions occur faster in this system. For a plug flow type reactor, the throughput is proportional to $1/t$, therefore, the relative gain in throughput for the test system, expressed in percentage is given by the following equation:

$$\Delta P = \left[\frac{1/t_2 - 1/t_1}{1/t_2} \right] \times 100 \quad (1)$$

The values of ΔP obviously can be calculated for different reactor temperatures and different end products (i.e. α values) provided experiments are carried out under controlled conditions.

Assessment of energy saving

To compare the energy requirements for a process using two sets of raw materials one should superimpose the two sets of α - t plots drawn in the same scale. Suppose the α - t plot at temperature, T_T for the test system appropriately matches with temperature T_R for the reference system (in this case T_T should be

less than T_R). Obviously, the test system accomplishes the same extent of reactions at lower temperatures therefore, saves energy (ΔE).

Heat losses depend on reactor temperatures. Assuming the loss as proportional to some function of temperature $f(T)$, we obtain for ΔE , expressed in percentage, an equation written as follows:

$$\Delta E = \left[\frac{f(T_R) - f(T_T)}{f(T_R)} \right] \times 100 \quad (2)$$

The exact form of the function can be determined experimentally. We can evaluate E for various temperature ranges for T_R to assess the variation of energy savings with respect to temperature.

The Eqs (1) and (2), of course, require some refinement. These are considered subsequently. This paper is devoted to a critical examination of use of Eq. 1 and Eq. 2 in the case of reduction of iron ore by gaseous and solid reductants under different experimental conditions.

The basic approach outlined can be applied in comparative assessment of the effect of any other variable which affects the reactivity of the system, therefore, the α - t plots. In a way, the approach approximates a null technique where an effect is measured as a function of a specific cause. The approach may be extended to α - t plots obtained under nonisothermal conditions also. For example, consider reduction of two ores under a given reducing environment, under an identical heating programme (Fig. 2). For a fixed degree of reaction, α , the gain in throughput for using the test system should be given by an equation similar to

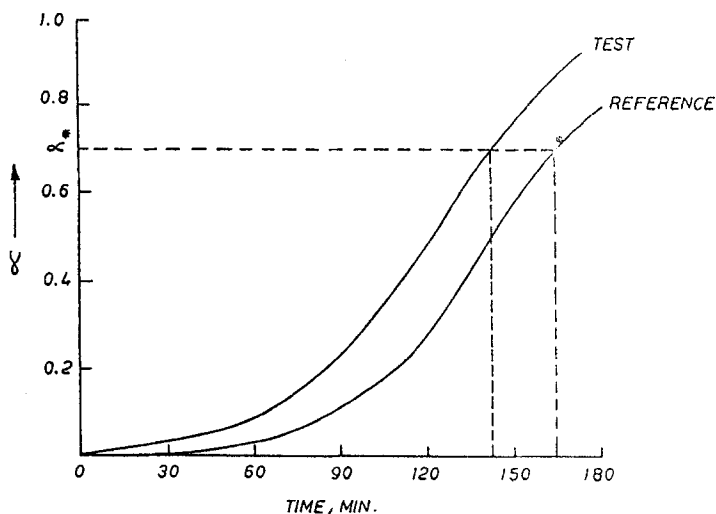

Fig. 2 Schematic non-isothermal kinetic plots for two raw materials under identical rate and programme of heating (test system more reactive than the reference system)

Eq. 1. In this case, however, it is not possible to compare the energy requirements easily.

Experimental

Reduction experiments have been carried out using a standard apparatus for determining the reducibility of iron ore, which is routinely used in National Metallurgical Laboratory, Jamshedpur, India. The set-up [Fig. 3(a)] described elsewhere [1, 3] generally makes use of isothermal reduction of iron ore by CO:N₂ (30:70) gas mixture. It can also be used, however, to study reaction by coal.

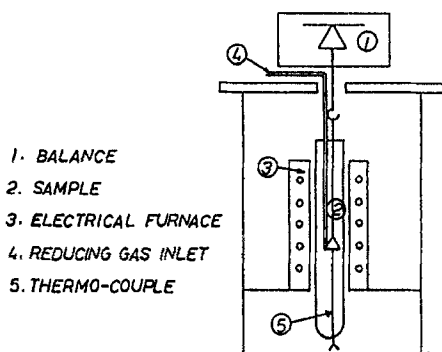

Fig. 3 (a) Schematic diagram of reducibility apparatus

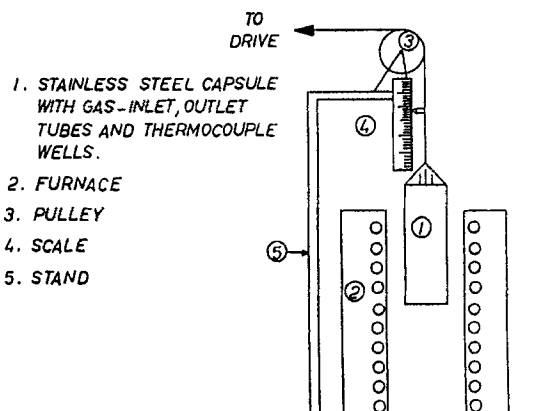

Fig. 3 (b) Schematic diagram of moving capsule set-up

Nonisothermal α - t plots were generated using a moving capsule set-up [Fig. 3(b)] now available at NML, Jamshedpur, India. The set-up and the prin-

ciples of operation have been described in detail elsewhere [4, 5]. The set-up consists of a cylindrical stainless steel capsule and within this a stainless steel cage which contains the reaction mixture. The capsule is introduced vertically downward into the hot zone of a furnace at a given speed. When the entire capsule is in, its movement is abruptly stopped, the capsule is removed, cooled, and samples taken from different locations along the length of the cage, are then analysed to obtain the degree of reaction at various depths within the reactor.

The ore used for this study was from Barajamda, and Gadigi area. The material was sieved into $-6+3$ mm size fraction. Each of these ores was analysed for their chemical constituents and the analyses are shown in Table 1.

Table 1 Chemical analyses of hematite ore (dry basis)

Material	% Fe (total)	% Fe (ous)	% SiO ₂	Al ₂ O ₃
Iron Ore (Barajamda)	68.8	5.1	1.10	0.81
Iron Ore (Gadigi)	67.0	5.8	1.10	1.50

The coal used in this study was an Indian non-coking coal from the seam of Raniganj field. The coal was also sieved in $-6+3$ mm size fraction. The proximate analysis of the coal is shown in Table 2.

Table 2 Proximate analysis of non-coking coal

Material	% Moisture	% Ash	% V.M.	% F.C.
coal (Raniganj)	7.0	17.5	31.0	44.5

Results and discussion

Gaseous reduction of iron ore

Some data reported by the authors [3] are considered here. Figure 4 shows data for a simpler situation of gaseous reduction of two different iron ores by a reducing gas (CO:N₂ = 30:70). The plots are all for isothermal runs. The experimental conditions, such as particle size, gas flow rate etc. held constant, are mentioned in the figure which summarizes the α - t plots for the two systems. Figure 5 replots the data shown in Fig. 4 as α vs. $1/t$ plots. We can now use these plots for relative assessment of throughput. The plots make it obvious that Gadigi ore is more reducible. Taking the Barajamda ore as reference, we can now obtain the relative gain in productivity for use of Gadigi ore for any given reactor temperature and any given product quality (i.e. fixed α value). For example, the $1/t$ values for α equal to 0.6 and temperature of 900°C are indicated in the Figs 4 and 5. One can now easily apply Eq. 1 to assess relative throughput values ΔP .

Figure 6 summarizes some ΔP values calculated for arbitrary values of α and reactor temperature.

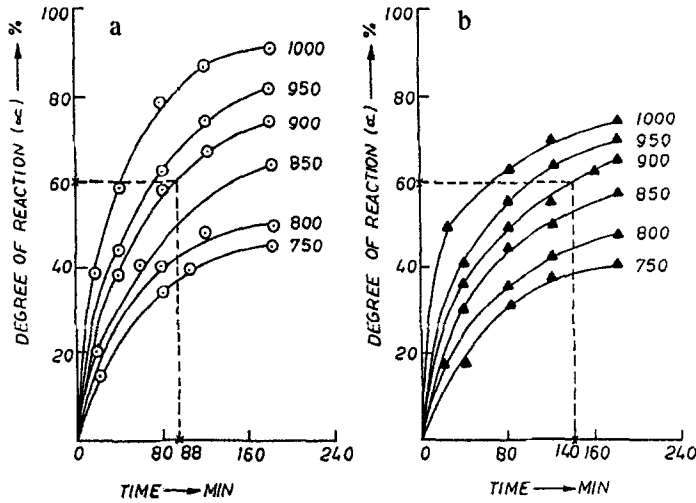

Fig. 4 α - t plots for reduction of iron ore by 30:70 mixture of CO and N₂
 a: Gaseous reduction of Gadigi ore, flow rate: 15 l/min, particle size: -6+3 mm,
 b: Gaseous reduction of Barajamda ore, flow rate: 15 l/min, particle size: -6+3 mm

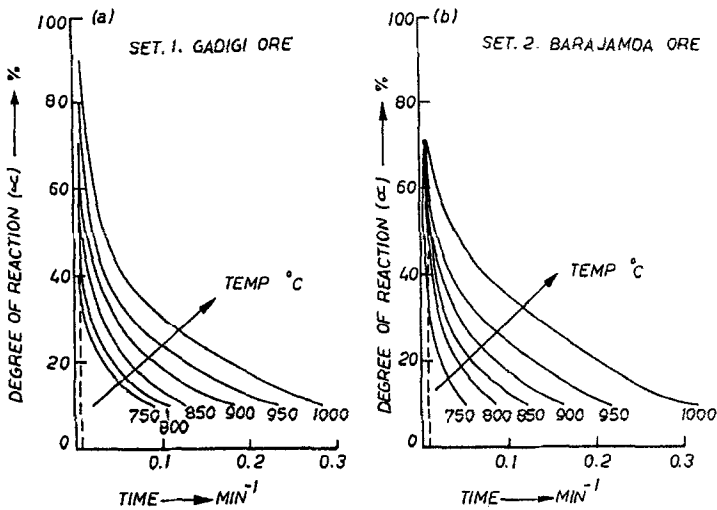

Fig. 5 α vs. $1/t$ plots obtained from the data shown in Fig. 4

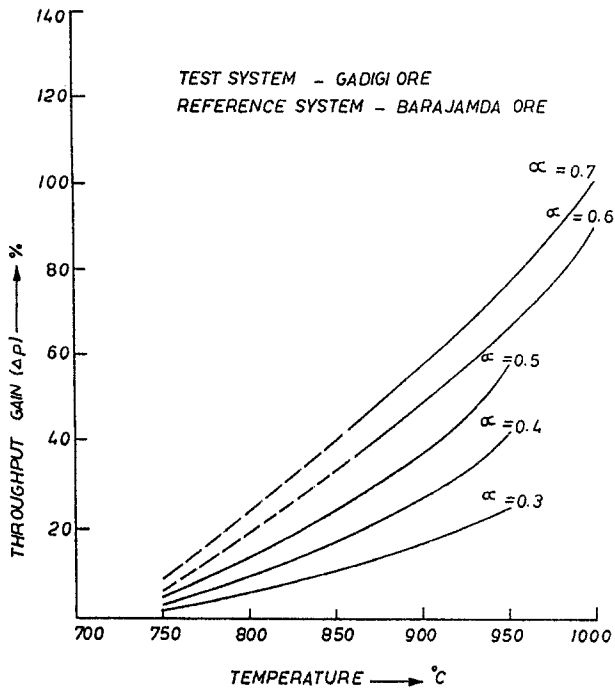

Fig. 6 ΔP - T plots for fixed different values of α , when gaseous reduction of Gadigi iron ore is compared to that of Barajamda iron ore

Energy aspects

To compare the energy requirements for reduction of the two ores, one must overlap Fig. 4(a) and 4(b) and determine the corresponding temperatures. Taking Barajamda ore as reference, one can then determine the ΔE values for different temperatures of the reference system by applying Eq. 2.

As mentioned earlier, the $f(T)$ in Eq. 2 was obtained through actual measurements of energy for reactors operating at different temperatures. Some experimental data are summarised in Fig. 7.

The plots show that, for energy, E is related to temperature T by an equation of the form:

$$E = \beta + v \cdot T \quad (3)$$

where β and v are constants. If β is taken as zero then E is directly proportional to T . This is the case in the type of furnace used in the present work. This means that the value of $f(T)$ in Eq. 2 is vT , where v is a constant. Thus the equation is rewritten as

$$\Delta E = \left[\frac{T_R - T_T}{T_R} \right] \times 100. \quad (4)$$

Applying this equation to overlapping plots of Fig. 4 one obtains Fig. 8. The figure shows that at lower temperatures there is a gain of 2–5% when one uses Gadigi ore. The gain increases with rise in process temperature attaining a limiting value of around 10%. For more accurate calculation one should ascertain the actual E vs. T plots for the reactors being used in the given process.

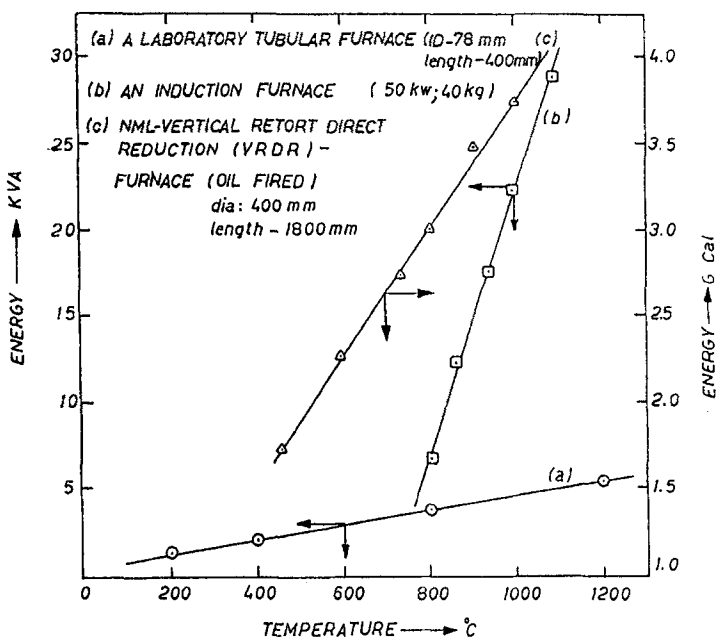

Fig. 7 Energy requirement for different process temperatures for three different reactors

Carbon reduction of iron ore

We now consider a more complicated system, namely, the iron ore-coal mixture. The reduction rate and, therefore, productivity of such a system depends on a number of factors such as ore/coal ratio, reducibility of ore and reactivity of coal/coke, particle size of solids etc. For brevity, we give here data for effect of ore/coal ratio only, all other factors remaining unchanged. Figure 9 summarizes the kinetic data for reduction of three mixtures of Barajamda ore and Raniganj coal as reported earlier by the authors [3].

Using the approach discussed earlier one can make a relative assessment of throughput values by considering reciprocal time values for a predetermined value of α . For example, if we take mixture C as the reference and $\alpha = 0.6$ as the

final desired quality then the reciprocal values of time for mixtures A, B and C, as shown, are respectively 0.038, 0.014 and 0.006. Therefore, compared to C, the

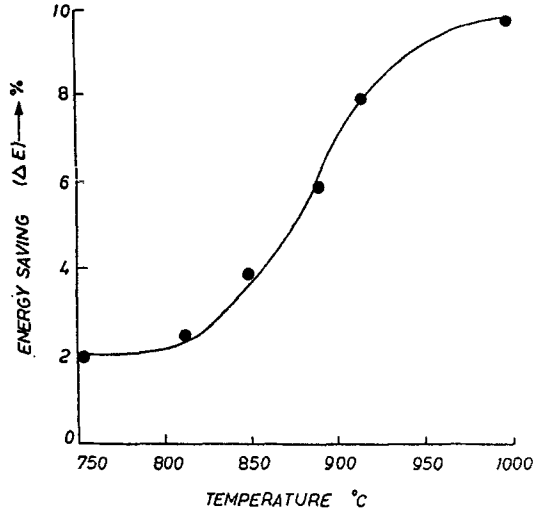

Fig. 8 Percent saving in energy for gaseous reduction of Gadigi ore as compared to Barajamda ore for different reference temperatures [values obtained by overlapping Fig. 4(a) and Fig. 4(b) and employing Eq. (2)].
Reference system: Barajamda ore. Test system: Gadigi ore

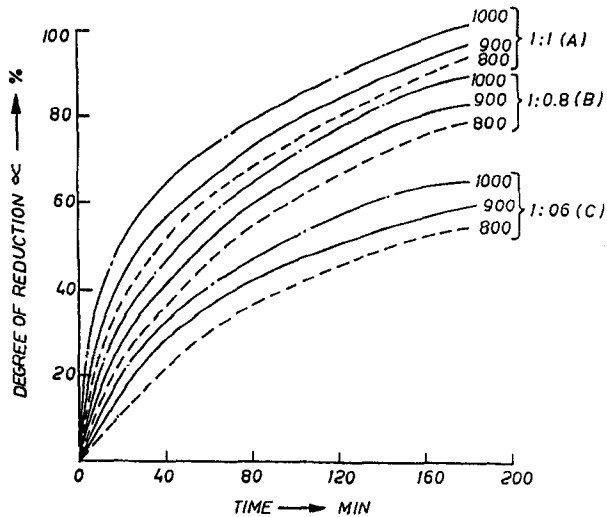

Fig. 9 Kinetic data for reduction of iron ore by coal in mixtures with varying ratio of ore/coal Barajamda ore / Raniganj coal temperature: 900°C, particle size ore: -6+3 mm, particle size coal: -6+3 mm, bulk density ore: 2.0, bulk density coal: 0.7

productivity of mixture B and that of A would be increased by 157% and 590% respectively.

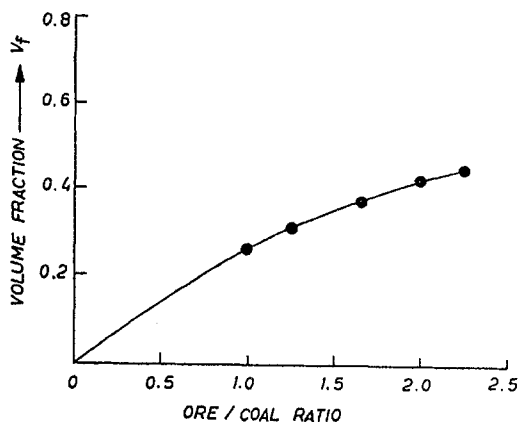

Fig. 10 Volume fraction occupied by ore in ore-coal mixtures varying ore/coal ratio (Particle size: -6+3 mm)

Normalization of data

There is, however, a serious error in this calculation. While increase in ore/coal ratio decreases the reduction rate, more ore is available in a given volume of the mixture. The decrease in reactivity is thus partly compensated by increased share of the volume of iron ore in the packed bed reactor. Similarly, while a decrease in ore/coal ratio tends to increase throughput by increasing the reactor rate, there is reduced productivity of iron because iron ore now occupies a lesser volume fraction of the ore-coal mixture. To eliminate the uncertainties all data must be normalized and expressed for a given amount or volume of either ore or coal.

Suppose that the ore/coal ratio	= x
Weight of ore	= W_o
Bulk density of ore	= ρ_o
Weight of coal	= $W_c = W_o/x$
Bulk density of coal	= ρ_c
Volume of packed bed reactor	= V

$$V = \left(\frac{W_o}{\rho_o} + \frac{W_c}{\rho_c} \right) = W_o \left(\frac{1}{\rho_o} + \frac{1}{x\rho_c} \right) \quad (5)$$

Volume fraction occupied by ore is given by the equation:

$$V_f = \left(\frac{W_o / \rho_o}{V} \right) = \left[\frac{W_o / \rho_o}{W_o \left(\frac{1}{\rho_o} + \frac{1}{x\rho_c} \right)} \right] \tag{6}$$

$$V_f = \left(\frac{1}{1 + \frac{\rho_o}{x\rho_c}} \right) \tag{7}$$

The bulk density values for ore and coal particles of the given size were measured to be 2.0 T/m³ and 0.7 T/m³ respectively. One can then calculate, using Eq. 6, the volume fraction occupied by ore particles in mixtures of different ore/coal ratios. Figure 10 shows the calculated values. The plot curves downwards because ore is heavier and proportionately occupies a lesser volume. All throughput-gain data should be corrected so as to relate to a fixed value of V_f^o. Thus the corrected form of Eq. 1 for the ore-coal mixture would be:

$$\Delta P = \{1 - (t_1/t_2)V_f^o\} \times 100 \tag{8}$$

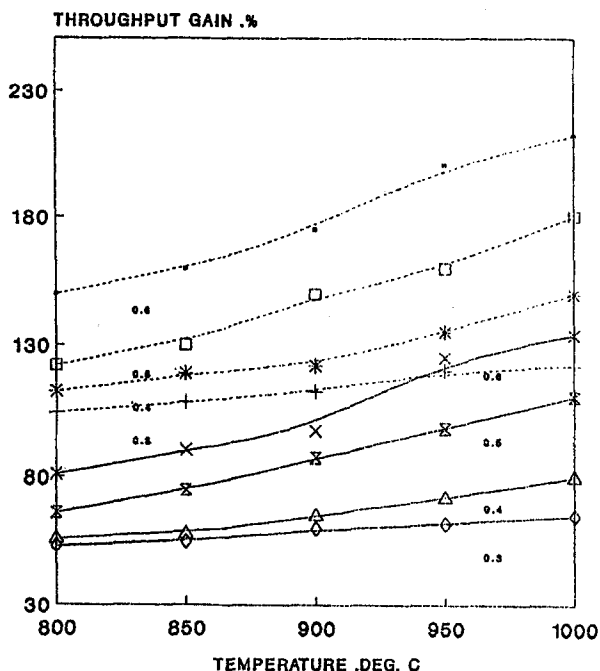

Fig. 11 Throughput-gain of ore-coal mixtures for ore/coal ratio 1:0.8 with respect to reference mixture with ore/coal = 1.0:0.6, --- without normalization, — with normalization

$$\text{where } V_f^o = \left(\frac{V_f^R}{V_f^T} \right)$$

V_f^T = volume fraction for test sample

V_f^R = volume fraction for ref. sample

Throughput values calculated on the basis of data shown in Fig. 9 and Fig. 10, are plotted with temperature for different values of degree of reaction, in Figs 11 and 12. The figures show throughput-gain of ore-coal mixtures for ore/coal ratio of 1.0:0.8 (Fig. 11) and 1.0:1.0 (Fig. 12) with respect to mixture for ore/coal ratio of 1.0:0.6. The rate of increase in throughput-gain increases with temperature in both the cases (ore/coal = 1.0:0.8; ore/coal = 1.0:1.0) however the magnitude of increase is about two fold in later case. This may be ascribed to the higher rate of gasification at higher temperatures and lower ore/coal ratios, and the reduction is thus carried out much faster than the reference material. However, on normalisation the magnitude of throughput-gain is small under identical conditions though the rate of increase in throughput increases with temperature and degree of reduction in either case. These results are also shown in Figs 11 and 12. The influence of decreasing ore/coal ratio i.e. corresponding decrease in volume fraction occupied by ore is offset by the enhancement in kinetics of reduction of iron ore. It

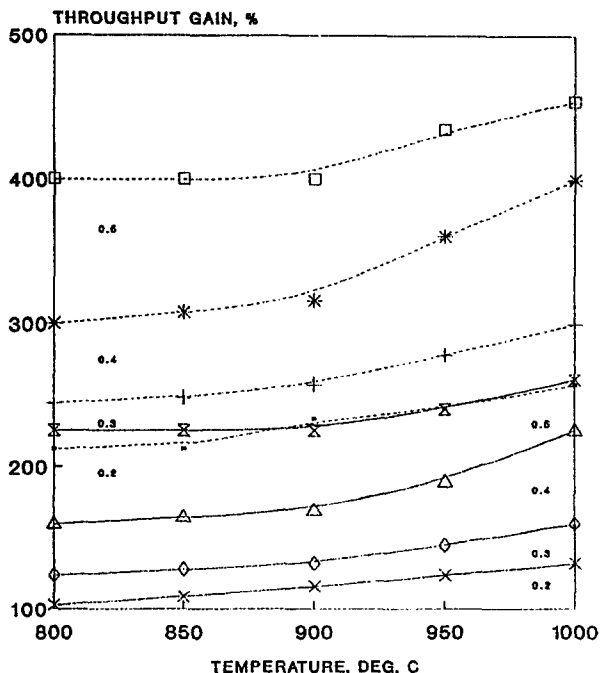

Fig. 12 Throughput-gain of ore/coal mixtures for ore/coal ratio 1:1.0 with respect to reference mixture with ore/coal = 1.0:0.6

--- without normalization, — with normalization

should be noted, however, that the trend perhaps reverse around the optimum ore/coal ratio beyond which further reduction would lower the throughput.

The energy aspect can also be examined if we analyse α - t plots for different temperatures for the different ore/coal mixtures.

Analysis of nonisothermal plots

As mentioned earlier nonisothermal kinetic plots obtained under controlled conditions, can be analysed for assessment of relative throughput values.

Figure 13 shows nonisothermal kinetic data generated from MBT [4]. It shows the variation of degree of reduction (α) with time for three different ore/coal ratios for a fixed particle size. In each case the temperature variation was identical for the capsule speed and the furnace temperature profile indicated. The data clearly demonstrated the effect of ore/coal ratio on reducibility. Under identical conditions, reduction is enhanced when the ore/coal ratio is decreased in the range studied. The coal and ore were same in all cases.

In this case the relative throughput (ΔP) values can be determined from the reaction time for each mixture for a fixed value of α by the use of Eq. 1. Figure 14 shows decrease in relative gain in throughput with degree of reduction for two sets of mixture (ore/coal = 1.0:1.0 and 1.0:0.8) with respect to third set taken as

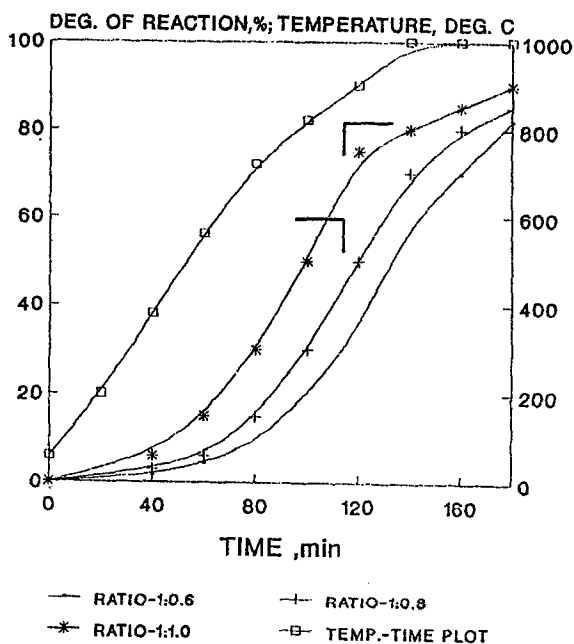

Fig. 13 Non-isothermal kinetic plots for reaction in three ore-coal mixtures of ratios = 1.0:0.6; 1.0:0.8; 1.0:1.0, ore: Barajamda; coal: Raniganj; particle size: $-6+3$ mm

reference (ore/coal=1.0:0.6), for data shown in Fig. 13. While the rate of decrease is identical in both the cases the magnitude of throughput gain is more in case of smaller ore/coal ratio. Again all throughput data should be normalized and correlated to a fixed value of V_f^0 employing Eq. (8). Normalized throughput data, as shown in Fig. 14, interestingly indicate that there is a throughput-loss. The rate of which increases with degree of reaction, though identically for both the test mixtures. This is not so in case of isothermal data analyses.

The energy aspects are also analysed employing Eq. 4. Figure 15 shows the energy and throughput analyses for data shown in Fig. 13 [4]. It shows that the relative gain in energy decreases with degree of reaction for both test mixtures. While the relative gain in energy decreases as higher degree of reduction is attained, the relative throughput-loss (normalized) increases in the range studied.

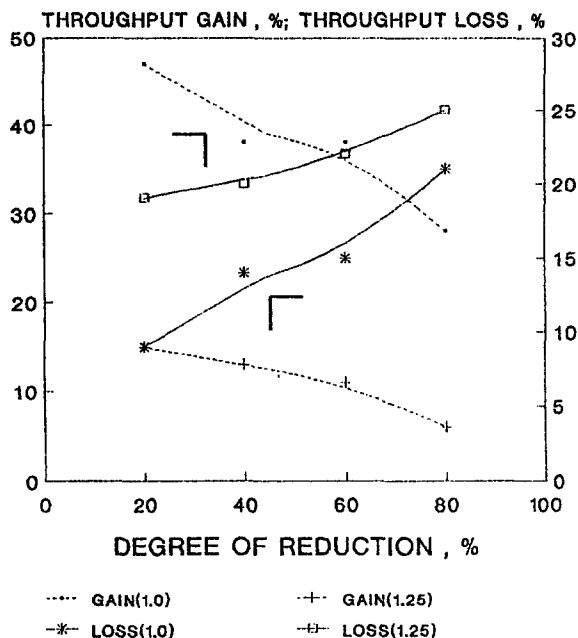

Fig. 14 Throughput change for ore-coal ratios 1.0:1.0 and 1.0:0.8 with respect to ore-coal ratio of 1.0:0.6 for data shown in Fig. 13; --- without normalization; — with normalization

It may be mentioned that in this case the temperature is changing with time. Therefore any assessment on throughput and/or energy consumption based on results shown in Figs 14 and 15 will only be suggestive. For more accurate calculations one should however analyse $\alpha-t$ plots for different temperatures for the different ore-coal mixtures.

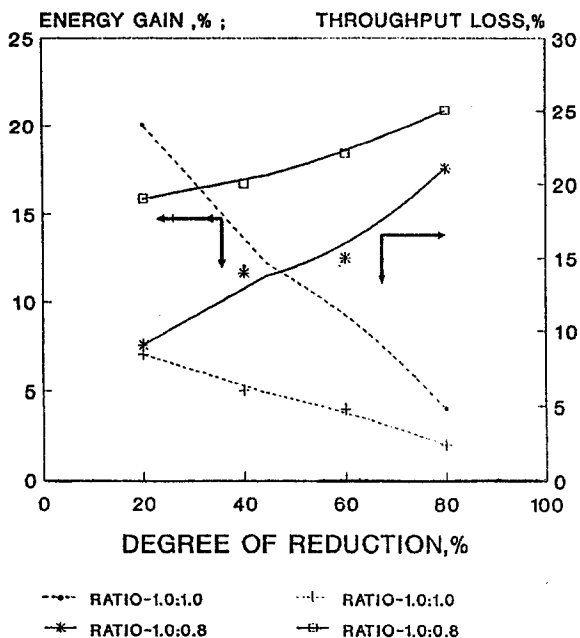

Fig. 15 Throughput and energy analyses for data in Fig. 13; --- energy; — throughput (normalized) reference ratio -1.0:0.6

Conclusions

It is shown that isothermal kinetics plots (α - t plots) for high temperature processes can be analysed for assessment of relative throughput values for a desired product (i.e. fixed α) at a desired temperature for different sets of raw materials. It is also possible to obtain, from these isothermal plots, approximate estimates in the energy saving as one moves from one set to another. This implies that relative gain in throughput is higher at terminal α values. Non-isothermal kinetic plots may also be made use of in the analyses of energy and throughput differences.

The basic general idea is potentially of wider application. Any parameter which reflects the progress of reaction unambiguously can be used provided it is measured as a function of time under controlled conditions.

* * *

The authors wish to thank Prof. P. R. Rao, Director National Metallurgical Laboratory, Jamshedpur, India, for providing facilities for experimental work and for according permission to publish this work.

References

- 1 S. Prakash, 'Studies on nonisothermal kinetics of iron ore reduction', Ph. D. Thesis submitted at Department of Metallurgical Engineering, IIT, Kharagpur, India, 1987, pp. 213–219
- 2 S. Prakash, H. S. Ray and K. N. Gupta, Proc. of the 5th National Symposium on Thermal Analysis, IIT Kharagpur, Dec. 20–25, 1985 V.5, pp. 5.16–5.20.
- 3 S. Prakash, H. S. Ray, Thermochem. Acta, 111 (1987) 143.
- 4 S. Prakash, H. S. Ray and K. N. Gupta, Ironmaking Steel-making, 13 (1986) 76.
- 5 S. Prakash, K. N. Gupta, V. A. Altekar and H. S. Ray, Progress in Metallurgical Research – Fundamental and Applied Aspects, Tata McGraw-Hill Publishing Co. Ltd., New Delhi, Feb. 11–15, 1985, India, p. 155–158.
- 6 S. Prakash, H. S. Ray and K. N. Gupta; React. Solids, 4 (1987) 215.
- 7 S. Prakash and H. S. Ray, ISIJ International, 30 (1990) p. 183-191.

Zusammenfassung — Das Voranschreiten von Hochtemperaturprozessen wird im allgemeinen als Funktion der Abhängigkeit des Konversionsgrades (α) von der Zeit (t) beschrieben. Vorliegende Arbeit umreißt ein Verfahren zur Anwendung von α - t -Diagrammen für eine vergleichende Einschätzung von Produktivität und Energieanforderungen für ein Testsystem auf der Basis einiger vereinfachender Annahmen. Man nimmt an, daß der Durchsatz umgekehrt proportional zur Reaktionszeit ist, wie z.B. im Falle von diskontinuierlichen Reaktoren und Pfropfenströmungsreaktoren. Weiterhin wird angenommen, daß der Energieverbrauch eine einfache Funktion der Prozeßtemperatur ist. Das umrissene Prinzip wird anhand einiger Labor-daten über die Reduktion von Eisenoxid durch Kohle illustriert.